

# Kelly KD Brushed Motor Controller User's Manual

## Devices Supported:

<b>KD24200</b>	<b>KD48200</b>	<b>KD72200</b>
<b>KD24201</b>	<b>KD48201</b>	<b>KD72201</b>
<b>KD24202</b>	<b>KD48202</b>	<b>KD72202</b>
<b>KD24203</b>	<b>KD48203</b>	<b>KD72203</b>
<b>KD24300</b>	<b>KD48300</b>	<b>KD72300</b>
<b>KD24301</b>	<b>KD48301</b>	<b>KD72301</b>
<b>KD24302</b>	<b>KD48302</b>	<b>KD72302</b>
<b>KD24303</b>	<b>KD48303</b>	<b>KD72303</b>
<b>KD24400</b>	<b>KD48400</b>	<b>KD72400</b>
<b>KD24401</b>	<b>KD48401</b>	<b>KD72401</b>
<b>KD24402</b>	<b>KD48402</b>	<b>KD72402</b>
<b>KD24403</b>	<b>KD48403</b>	<b>KD72403</b>
	<b>KD48500</b>	<b>KD72500</b>
	<b>KD48501</b>	<b>KD72501</b>
	<b>KD48502</b>	<b>KD72502</b>
	<b>KD48503</b>	<b>KD72503</b>

# Contents

Chapter 1	Introduction.....	2
1.1	Overview.....	2
Chapter 2	Main Features and Specifications.....	3
2.1	General functions.....	3
2.2	Features.....	3
2.3	Additional Features (Terminals available on back side).....	3
2.4	Specifications.....	4
2.5	Models.....	4
Chapter 3	Wiring and Installation.....	5
3.1	Mounting the Controller.....	5
3.2	Connections.....	7
3.3	Installation Checkout.....	13
Chapter 4	Maintenance.....	14
4.1	Cleaning.....	14
Table 1:	LED CODES.....	15
Contact Us:	.....	16

# Chapter 1 Introduction

## 1.1 Overview

This manual introduces the Kelly motor controllers' features, their installation and their maintenance. Read the manual carefully and thoroughly before using the controller. If you have any questions, please contact the support center of Kelly Controls.

Kelly's programmable motor controllers provide efficient, smooth and quiet controls for electric vehicles like golf carts, electric motorcycles and forklifts, as well as electric boat and industrial motor speed control. It uses high power MOSFET's and, fast PWM to achieve efficiencies of up to 99% in most cases. A powerful microprocessor brings in comprehensive and precise control to the controllers. It also allows users to adjust parameters, conduct tests, and obtain diagnostic information quickly and easily.

## Chapter 2 Main Features and Specifications

### 2.1 General functions

- (1) The controller measures battery voltage. It won't drive motor if B+ is higher than the maximum operating voltage. It also stops driving if battery voltage is too low. You can identify the error from LED codes. Under voltage threshold and over voltage threshold are configurable with PC GUI.
- (2) The controller will close the main contactor after power on self-test. Then it waits a configurable time (configurable, default to 0.5s) for contactor bumping.
- (3) Current loop and over current protection are built in for both field and armature. The field current is constant across all operation conditions except in the case of field weakening. Armature current is commanded by throttle.
- (4) The armature current is trimmed down at low temperature and high temperature to protect battery and controller. The armature current begins to ramp down at 90°C. Both armature and field will shut down at 100°C.
- (5) Current cutback at low battery is built in every controller to extend battery life. **Caution!** *Excessive voltage drop on wiring may cause problem! Proper gauge of wire is required.*
- (6) The max regeneration current is about half of rated current. **Caution!** *Regeneration can have braking effect, but it can't replace mechanical brake. The controller may shut down regen in some cases.*
- (7) Maximum reverse speed is configurable to half of the maximum forward speed.

### 2.2 Features

- Intelligence with powerful microprocessor,
- Synchronous rectification, fast PWM, and ultra low drop to provide high efficiency.
- Rugged aluminum housing for maximum heat dissipation and harsh environment.
- Current loop and over current protection for both field coil and armature.
- Current multiplication. Usually the armature current is much higher than the current drawn from battery.
- LED blinking code indicates fault sources.
- Battery protection: current cutback and turnoff when battery voltage is too low.
- Thermal protection: current cuts back at high temperature and low temperature to protect battery and controller.
- Support torque mode operation.
- Configuring current-voltage mode of field function on controller with field to achieve more reliable.
- Critical parameters can be configured with GUI to best fit your application.
- User program provided. Easy to use. No cost to customers.

### 2.3 Additional Features (Terminals available on back side)

Following features are configurable through series communication with a host PC.

- "MAIN RLY" can be configured as a Peak and Hold Main Contactor coil driver.
- "BEEP/MTR" can be configured to drive reverse alarm or current meter. Can drive Kelly

Ammeter directly.

- BRK-SW as Brake Switch is required for regeneration.
- BRK-AN as Brake analog input can be configured for continuous variable regeneration.
- TPS2-AN can be configured as alternative throttle input. 3-wire pot or 0-5V sensor can work with the input. Please configure as 0-5V throttle should the pin be used.
- Optional Waterproof.

## 2.4 Specifications

- Frequency of Operation: 16.6 KHz.
- Standby Battery Current: < 0.5mA.
- Controller power supply current, PWR, <150mA.
- Controller supply voltage range, PWR, 18V to 90V (8V to 30V for 24V controller).
- Minimum operating voltage, B+, 18V (8V for 24V controller).
- Max regeneration voltage, B+, 1.25\* Nominal.
- Throttle Input: 0-5 K, 5-0 K ohms, 0-5 Volts.
- Full Power Operating Temperature Range: 0 °C to 50 °C (controller case temperature).
- Operating Temperature Range: -30 °C to 90 °C, 100 °C shutdown(controller case temperature).
- Peak and Hold Main Contactor Driver: 3A peak, 1A hold.
- Alarm Output: 200mA.
- Armature Current Limit, 1 minute: 200- 500A, depending on the model.
- Armature Current Limit, continuous: 80-200A, depending on the model.

## 2.5 Models

The naming regulations of the Kelly motor controller model:

# KD48301

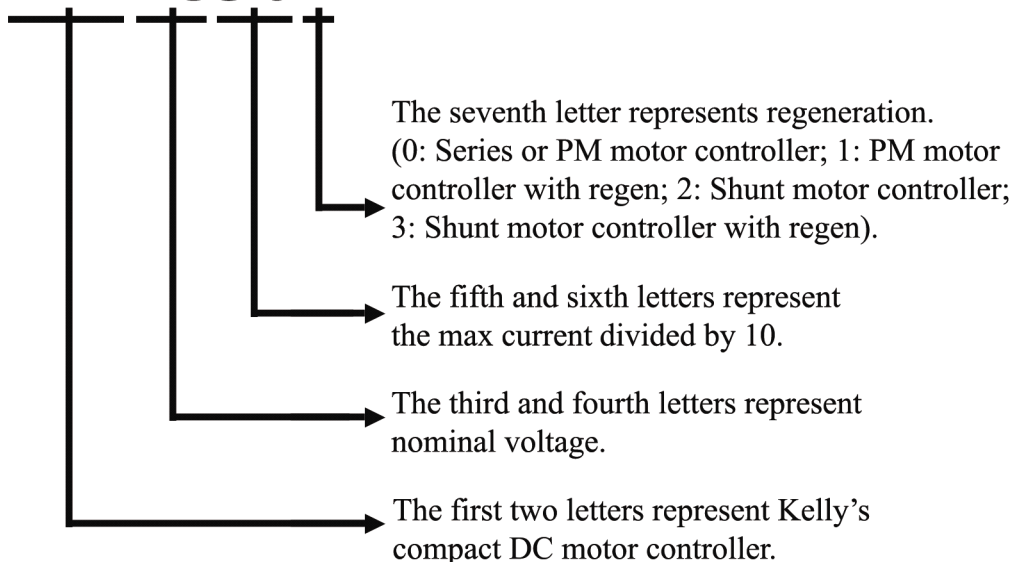

## Chapter 3 Wiring and Installation

### 3.1 Mounting the Controller

The controller can be oriented in any position which should be as clean and dry as possible, and if necessary, shielded with a cover to protect it from water and contaminants.

To ensure full rated output power, the controller should be fastened to a clean, flat metal surface with four screws. A thermal joint compound can be used to improve heat conduction from the case to the mounting surface. The case outline and mounting holes' dimensions are shown in Figure 1.

#### **Caution:**

- **RUNAWAYS** — Some conditions could cause the vehicle to run out of control. Disconnect the motor, or jack up the vehicle, and get the drive wheels off the ground before attempting any work on the motor control circuitry.
- **HIGH CURRENT ARCS** — Electric vehicle batteries can supply very high power, and arcs can occur if they are short circuit. Always turn off the battery circuit before working on the motor control circuit. Wear safety glasses, and use properly insulated tools to prevent short circuit.

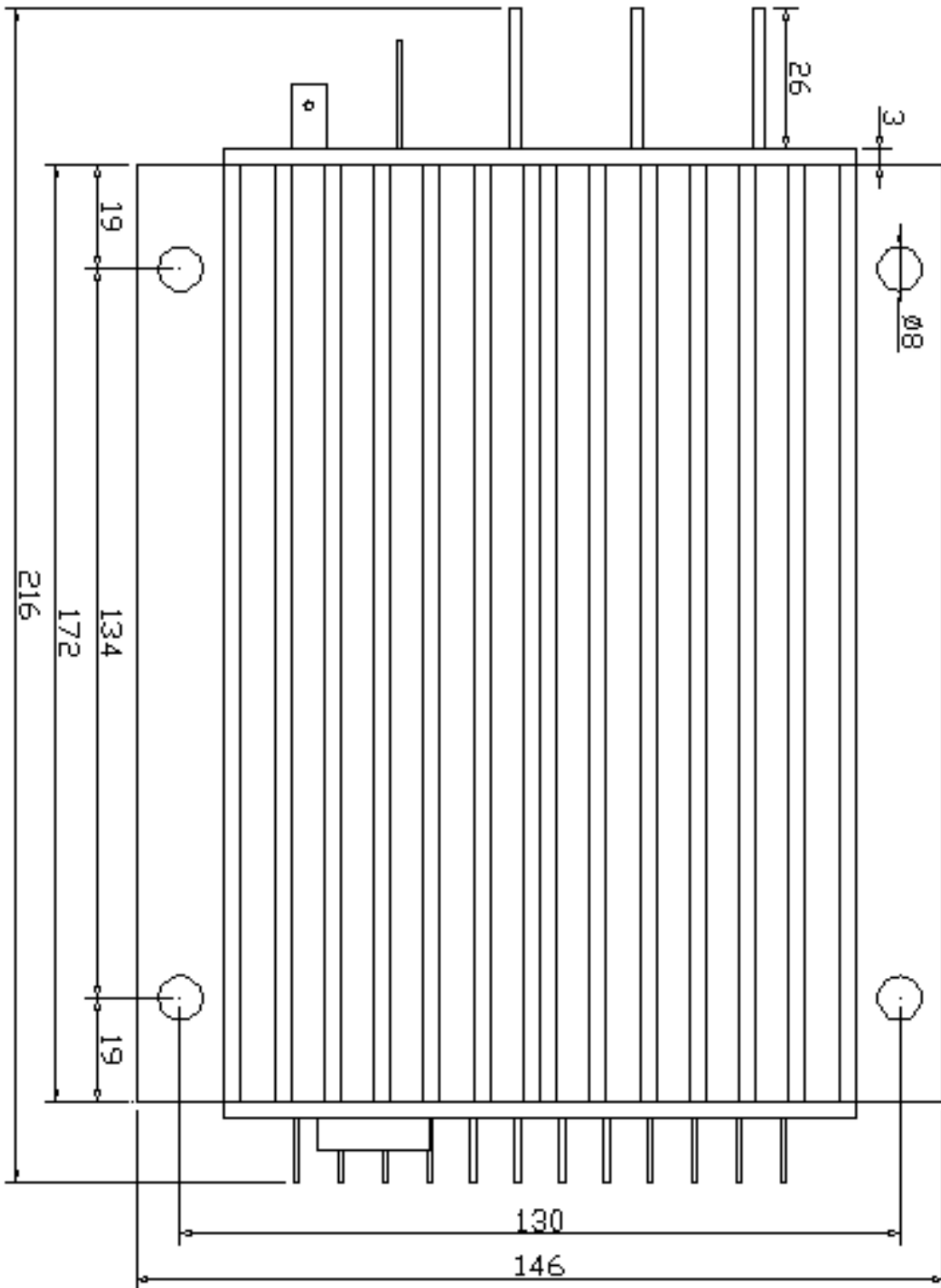

Height: 62 millimeters

**Figure 1:** Dimensions (in millimeters)

## 3.2 Connections

### 3.2.1 Front Panel of Series Wound or PM Motor Controller:

Seven metal bars are provided for connecting to the battery, motor and control signals in the front of the controller shown as Figure 2.

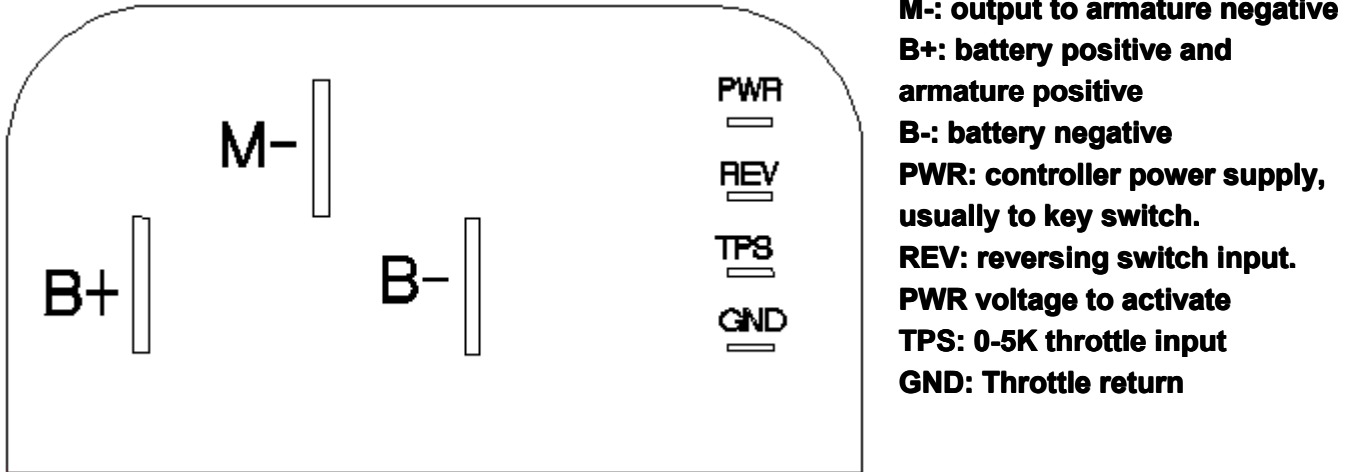

**M-: output to armature negative**  
**B+: battery positive and armature positive**  
**B-: battery negative**  
**PWR: controller power supply, usually to key switch.**  
**REV: reversing switch input.**  
**PWR voltage to activate**  
**TPS: 0-5K throttle input**  
**GND: Throttle return**

**Figure 2:** Front panel of Series Wound or PM Motor Controller

#### Caution:

- **Do not apply power until you are certain the controller wiring is correct and has been double checked. Wiring faults will damage the controller.**
- **Ensure that the B- wiring is securely and properly connected before applying power.**
- **The preferred connection of the system contactor or circuit breaker is in series with the B+ line.**
- **All contactors or circuit breakers in the B+ line must have precharge resistors across their contacts. Lack of even one of these precharge resistors may severely damage the controller at switch-on.**

**1. Power switch:** The vehicle should have a master switch to turn the controller on and off. PWR provides power for the controller. It is preferred that PWR provides power to switches, coils and other accessories. The wire and fuse must be capable of carrying the current.

**2. Reversing switch input:** Make sure the throttle is released before changing direction, or controller will stop output. It is considered as reverse if the input  $> 0.7 \cdot \text{PWR}$ .

**3. Resistive throttle analog input:** 0-5K or 5-0K resistive throttle input. Default to 0-5K. Default effective zone is 20%-80%. Below 1K corresponds to zero speed and above 4K corresponds to full speed. If open, controller will take TPS2-AN 0-5V input as alternative.

### 3.2.2 Standard Wiring of Series Wound and PM Motor Controller

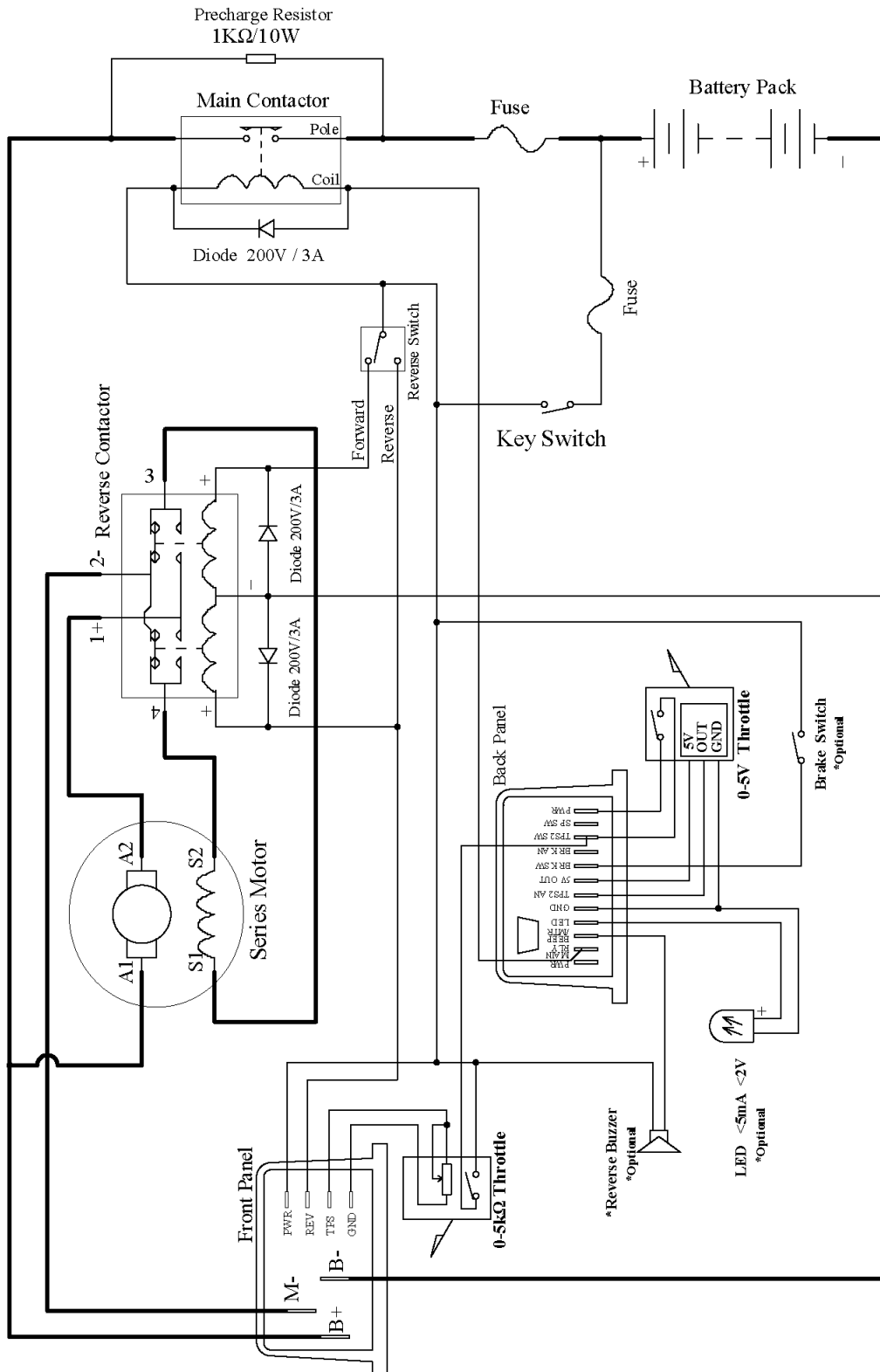

NOTE: Either 0-5K Resistive Throttle to TFS Or 0-5V Throttle to TFS2\_AN.  
 Please securely wire B- before any other wiring. Never put contactor or break on B-. It's preferred to wire B- to chassis.  
 When you connect an external LED, the LED back panel brightness will be reduced.

**Figure 3:** Series wound motor controller standard wiring

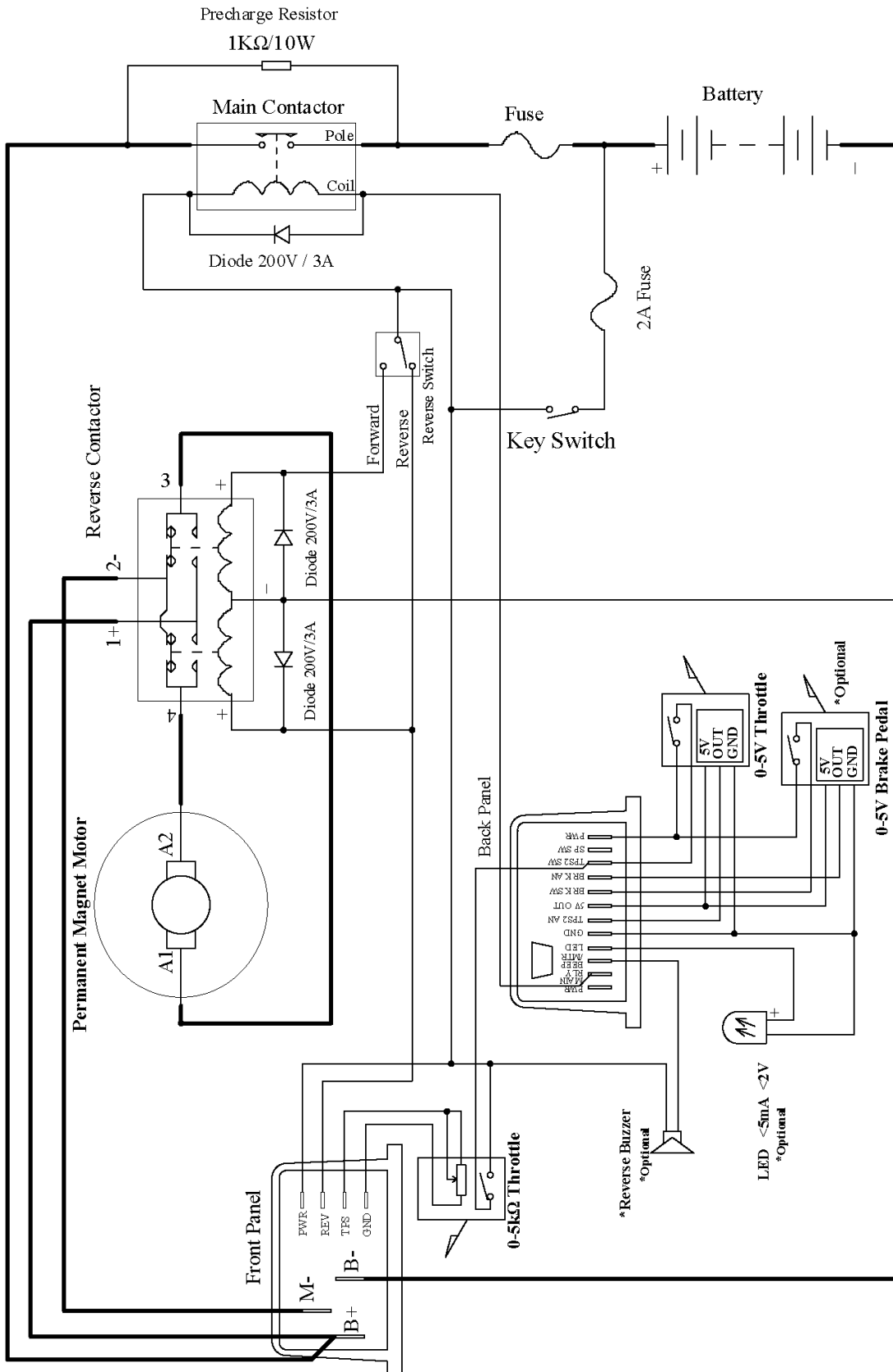

NOTE: Either 0-5K Resistive Throttle to TFS Or 0-5V Throttle to TFS2. AN.  
 Please securely wire B- before any other wiring. Never put contactor or break on B-. It's preferred to wire B- to chassis.  
 When you connect an external LED, the LED back panel brightness will be reduced.

Figure 4: PM motor controller standard wiring

### 3.2.3 Front Panel of Sep/Ex and Shunt Motor Controller:

Nine metal bars are provided for connecting to the battery, control signals, motor armature and field in the front of the controller.

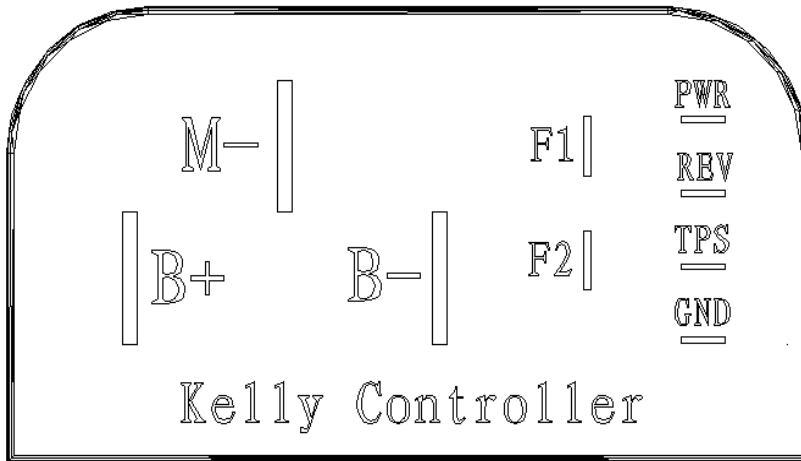

**M-: output to armature negative**  
**B+: battery positive and armature positive**  
**B-: battery negative**  
**F1: field positive**  
**F2: field negative**  
**PWR: power switch input**  
**REV: reversing switch input**  
**TPS: resistive throttle analog input**  
**GND: sensor return**

**Figure 5:** Front Panel of Shunt Motor Controller

- 1. Power switch:** The vehicle should have a master switch to turn the controller on and off. PWR provides power for the controller. It is preferred that PWR provides power to switches, coils and other accessories. It must be capable of carrying the current.
- 2. Reversing switch input:** Make sure the throttle is released before changing direction, or controller will stop output. It is considered as reverse when the input reaches  $0.7 \cdot \text{PWR}$  voltage
- 3. Resistive throttle analog input:** 0-5K or 5-0K resistive throttle analog input. Default to 0-5K. Default effective zone is 20%-80%. Below 1K corresponds to zero speed and above 4K corresponds to full speed. If open, controller will take AN2 0-5V input as alternative.
- 4. F1 and F2:** Connect to motor field coil. Motor moves forward when current flow from F1 to F2, in the case of REV switch open.



### 3.2.5 Back Panel:

Twelve metal bars and a communication port are provided on the back panel of each controller shown as Figure 7.

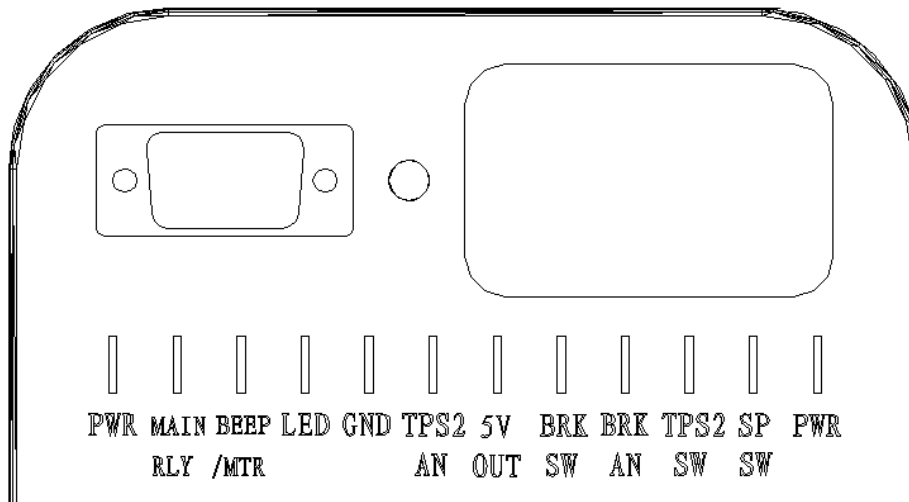

**Figure 7:** Back Panel of all Controllers

**PWR:** Controller power supply (output).

**MAIN RLY:** main contactor coil driver.

**BEEP/MTR:** can drive either reverse alarm or Kelly Ampmeter. Default is reverse alarm. Configured as current meter. Kelly Ampmeter positive connect to 5V OUT, negative to BEEP/MTR.

**LED:** LED anode

**GND:** LED cathode and sensor return

**TPS2 AN:** 0-5V throttle analog input, as alternative of 0-5K TPS input.

**5V OUT:** +5V 30mA output as supply to throttle or brake sensors.

**BRK SW:** brake switch input, active when apply PWR voltage

**BRK AN:** 0-5V brake analog input.

**TPS2 SW:** throttle switch input, active when apply PWR voltage

**SP SW:** reserved switch input, active when apply PWR voltage

### 3.2.6 Communication Port

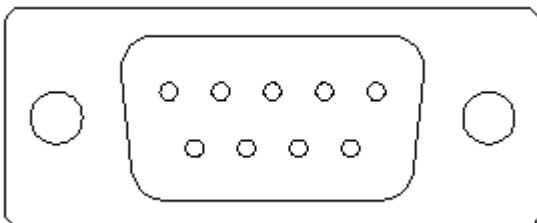

A SCI port is provided to communicate with RS232 of host computer for calibration and configuration. Please note only a special RS232 Converter provided by Kelly Controls can be used. Please use straight RS232 cable to connect with PC

Download the free configuration software from:

<http://www.kellycontroller.com/support.php>

**Caution:**

- Make certain that the motor is disconnected before trying to run the Configuration software!
- Configuration software will be regularly updated and published on the website. Please update your Configuration Software regularly. You must uninstall the older version before updating.

### 3.3 Installation Checkout

Before operating the vehicle, complete the following checkout procedures. Use LED code as a reference as listed in Table 1.

**Caution:**

- Put the vehicle up on blocks to get the drive wheels off the ground before beginning these tests.
- Do not allow anyone to stand directly in front of or behind the vehicle during the checkout.
- Make sure the PWR switch and the brake is off
- Use well-insulated tools.

- Make sure the wire is connected correctly
- Turn the PWR switch on. The LED should blink, then stay on steadily when the controller operates normally. If this does not happen, check PWR voltage and controller ground.
- The fault code will be detected automatically at restarting.
- With the brake switch open, select a direction and operate the throttle. The motor should spin in the selected direction. If it does not, verify the wiring to the REV switches, REV contactors, Main contactor and motor. Also check fuse. The motor should run faster with increasing throttle. If not, refer to Table 1 LED code, and correct as determined by the fault code.
- Take the vehicle off the blocks and drive it in a clear area. It should have smooth acceleration and good top speed.

## Chapter 4 Maintenance

There are no user-serviceable parts inside the controllers. Do not attempt to open the controller as this will void your warranty. However, periodic, exterior cleaning of the controller should be carried out.

The controller is a high powered device. When working with any battery powered vehicle, proper safety precautions should be taken. These include, but are not limited to, proper training, wearing eye protection, avoidance of loose clothing, hair and jewelry. Always use insulated tools.

### 4.1 Cleaning

Although the controller requires actually no maintenance after properly installed, the following minor maintenance is recommended in certain applications.

- Remove power by disconnecting the battery, starting with battery positive.
- Discharge the capacitors in the controller by connecting a load (such as a contactor coil or a horn) across the controller's B+ and B- terminals.
- Remove any dirt or corrosion from the bus bar area. The controller should be wiped down with a moist rag. Make sure that the controller is dry before reconnecting the battery.
- Make sure the connections to the bus bars, if fitted, are tight. To avoid physically stressing the bus bars use two, well-insulated wrenches.

**Table 1: LED CODES**

LED Code		Explanation	Solution
Off	████████	No power or switched off	<ol style="list-style-type: none"> <li>1. Check if all wires are correct.</li> <li>2. Check fuse and power supply switch.</li> </ol>
On	□□□□□□	Normal operating	That's great! You got solution!
1,2	▣    ▣▣	Over voltage error	<ol style="list-style-type: none"> <li>1. Battery voltage is too high for the controller. Check battery volts and configuration.</li> <li>2. Regeneration over-voltage. Controller will have cut back or stopped regen.</li> <li>3. This only accurate to <math>\pm 2\%</math> upon Overvoltage setting.</li> </ol>
1,3	▣    ▣▣▣	Low voltage error	<ol style="list-style-type: none"> <li>1. The controller will clear after 5 seconds if battery volts returns to normal.</li> <li>2. Check battery volts &amp; recharge if required.</li> </ol>
1,4	▣    ▣▣▣▣	Over temperature warning	<ol style="list-style-type: none"> <li>1. Controller case temperature is above 90°C. Current will be limited. Reduce controller loading or switch Off until controller cools down.</li> <li>2. Clean or improve heatsink or fan.</li> </ol>
2,1	▣▣    ▣	Throttle sensor fault	<ol style="list-style-type: none"> <li>1. Check if all wires are correct.</li> <li>2. Check if the throttle type is correct.</li> <li>3. Check if the voltage is above 5V when use 0-5V hall throttle.</li> <li>4. Check configured throttle type. TPS2 should be configured as voltage input if used.</li> </ol>
2,2	▣▣    ▣▣	Internal volts fault	<ol style="list-style-type: none"> <li>1. Measure that B+ &amp; PWR are correct</li> <li>2. There may be excessive load on the +5V supply.</li> </ol>
2,3	▣▣    ▣▣▣	Over temperature	The controller temperature has exceeded 100°C. The controller will be stopped but will restart when temperature falls below 80°C.
2,4	▣▣    ▣▣▣▣	Throttle error at power-up	<ol style="list-style-type: none"> <li>1. The throttle got effective signal at key-on. Fault clears when throttle is released. You may reconfigure throttle effective range or foot switch.</li> <li>2. The acceleration throttle must be turned from zero up to high when the brake is released. Otherwise the controller will report this fault.</li> </ol>
3,1	▣▣▣    ▣	Frequent Reset	May be caused by over-voltage, bad motor intermittent earthing problem, bad wiring, etc.
3,2	▣▣▣    ▣▣	Internal reset	May be caused by some transient fault condition like a temporary over-current, momentarily high or low battery voltage. This can happen during normal operation.
3,4	▣▣▣    ▣▣▣▣	Non-zero throttle	Controller won't allow a direction change unless the

		on direction change	throttle or speed is at zero. Fault clears when throttle is released.
4,1	□□□□ □	Regen over-voltage	The voltage is higher than the configured overvoltage value. The controller can resume operation when voltage lowered and brake cycled.
4,2	□□□□ □□	Field error	1. Field did not reach the configured current. 2. Field circuit open. Please check field wiring.
<p>The LED flashes once at power on as a confidence check and then stays on for normal operation. "1, 2" means the Red flashes once and after a second pause, flashes twice. The time between two flashes is 0.5 second. The pause time between multiple flash code groups is two seconds.</p>			

## Contact Us:

**Kelly Controls, LLC**

**Home Page:**

<http://www.kellycontroller.com>

**E-mail:**

[support@kellycontroller.com](mailto:support@kellycontroller.com)

**Phone:**

(001) 224 637 5092